

# METER NANO T

EN 16882

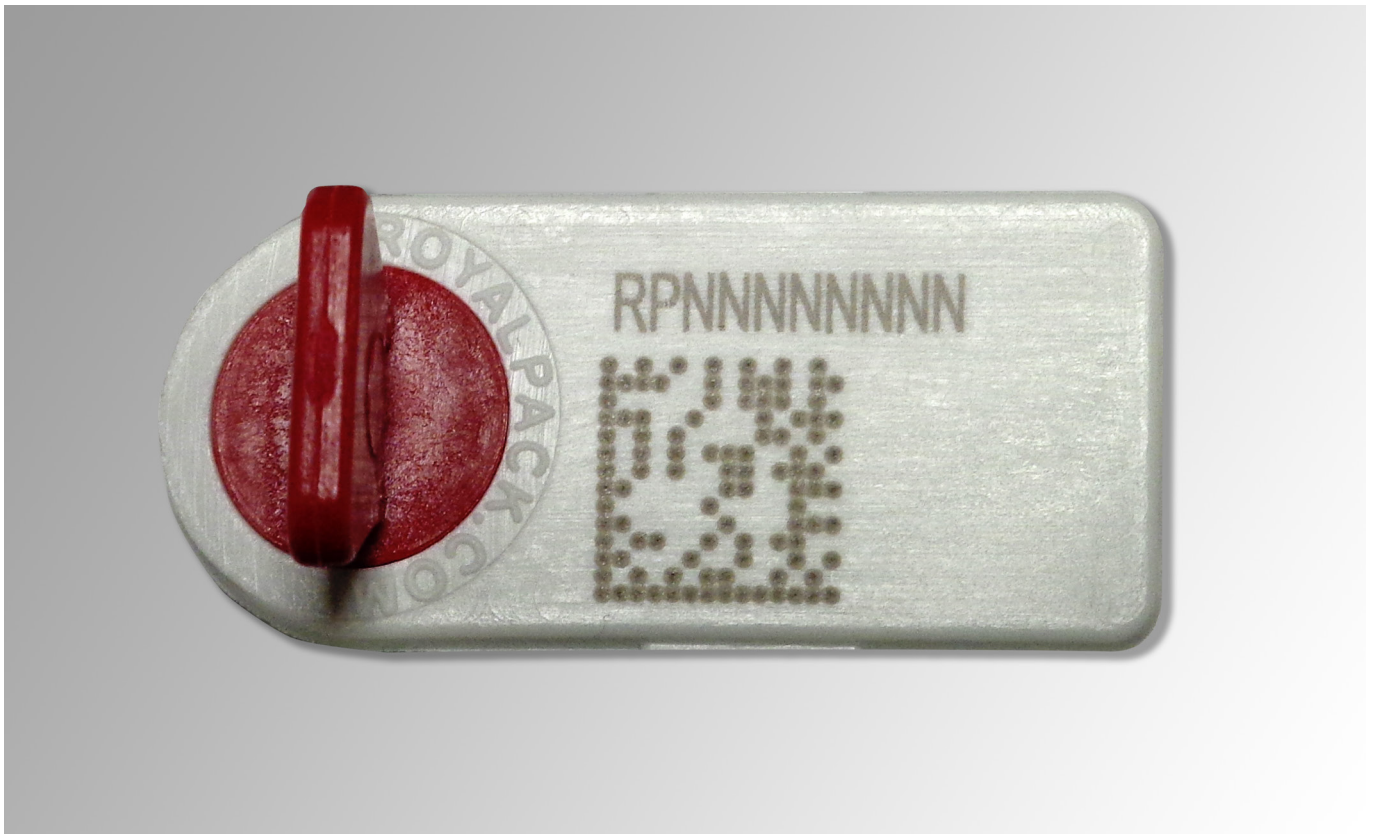

T logo engraved



Manufacturer identification engraved



Oversized entry holes

Safety seal specially designed for use in the sealing of the sensor of the gearbox of commercial vehicles.

Certified according to the European Standard EN 16882.

## Features

Security seal with rotor type closure with visual tampering evidence.

T logo engraved.

Manufacturer identification engraved.

Oversized and countersunk entry holes to facilitate threading.

Applied by hand, auxiliary tools are needless for operate.

Presentation in combs of 10 units to facilitate their selection and traceability.

Application with wire of desired length.

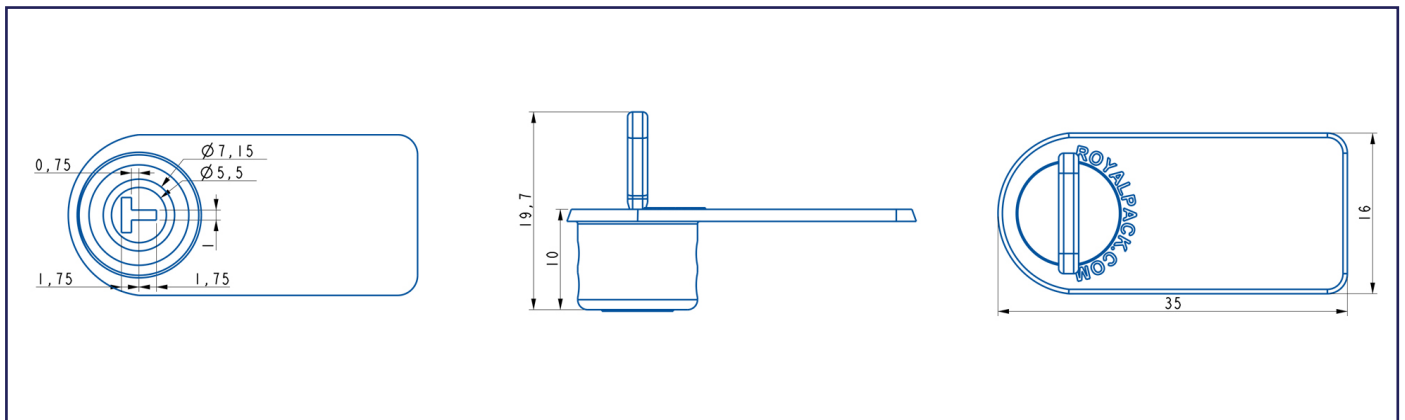

Material	Printing	Options	Features	Packaging
<b>Body and rotor:</b> PA	Laser printing Printing area: 15 x 21 mm	Bar code Datamatrix code QR code	Visual tampering evidence Oversized holes	10 units combs. <b>1.000 units boxes:</b> 22 x 32 x 19 cm 2 kg – 0,013 m <sup>3</sup>